

## BANDE DE GUIDAGE PMR

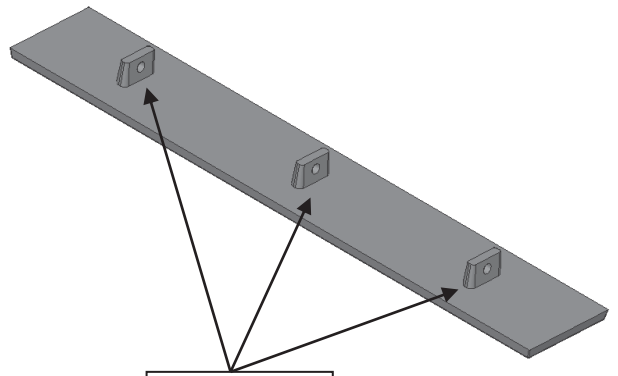
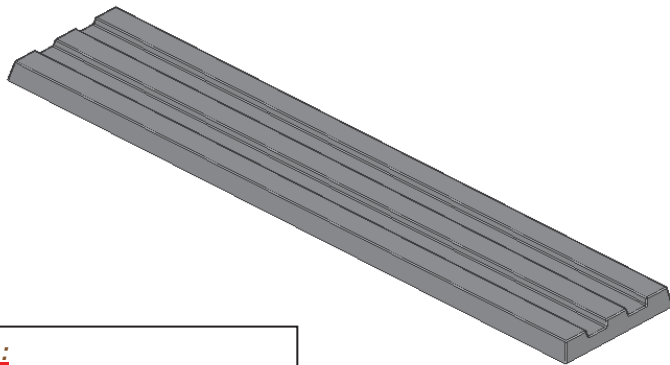

Patte de scellement

**MATIERE :**

FRONTE EN – GJS – 500 – 7

**RETEMENT :**

Revetement provisoire de peinture hydrodiluable

**OPTION :**

Allonge de scellement



CODE	A	B	C	H	E
22352AV	500	100	20	15	5

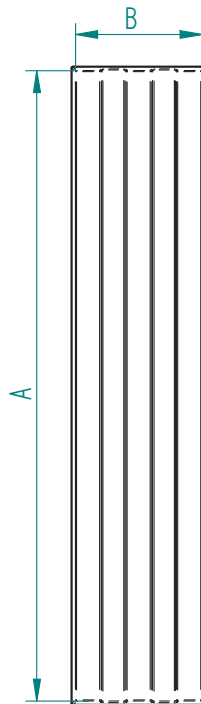
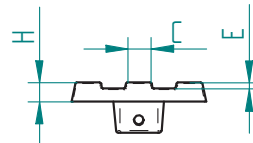

Tolérance Dimensionnelle : ISO 8082-3 DCTG12	INDICE	00
	DATE	23/03/2018
	REDACTEUR	JC
	VISA	BT